



New **KOMPRESSOR ARRAY** Technology  
by **Zingali Acoustics**

*An evolution of Omniday Technology*

*Quantum Array Series*

Since its origins, *Zingali Acoustics S.p.A.* has always tried to innovate with revolutionary technologies, such as with *Omniray Technology* patented in 1995.

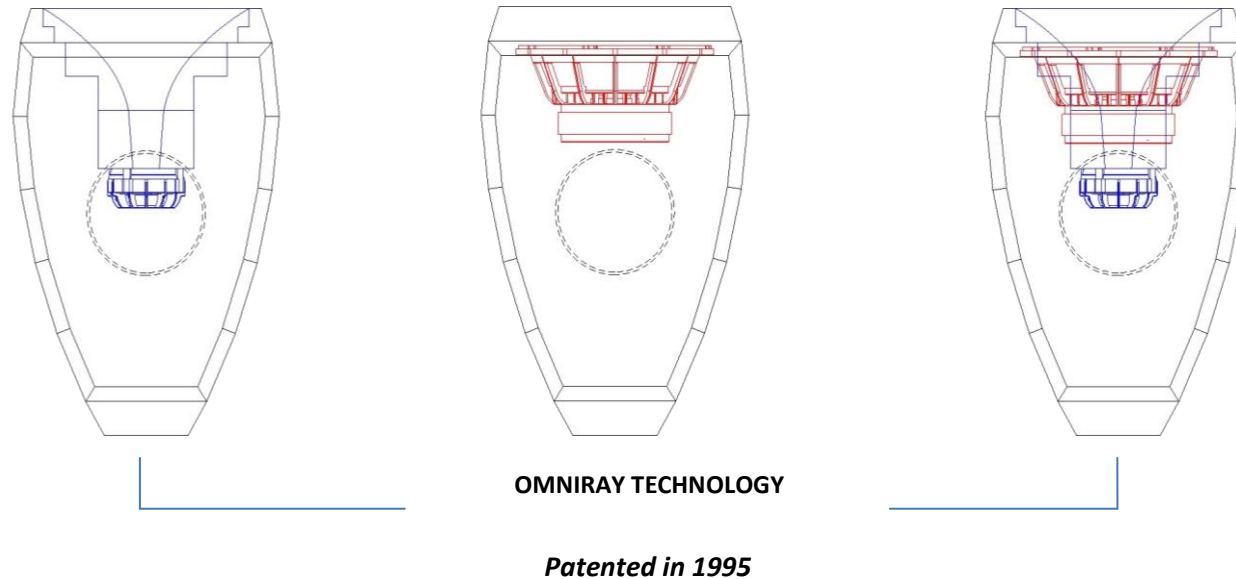

For over 20 years, this technology has allowed our loudspeakers to have a unique sound for both dynamics and detail, with respect to conventional horn systems that use compression drivers.

As it is known to all our audiophile customers around the world, *Omniray Horn Technology* has offered a realistic and dynamic sound over the years, but without the nasal effect typical of all other conventional horn systems, a feature this last one, that it is not appreciated by audiophiles.

## KOMPRESSOR ARRAY TECHNOLOGY

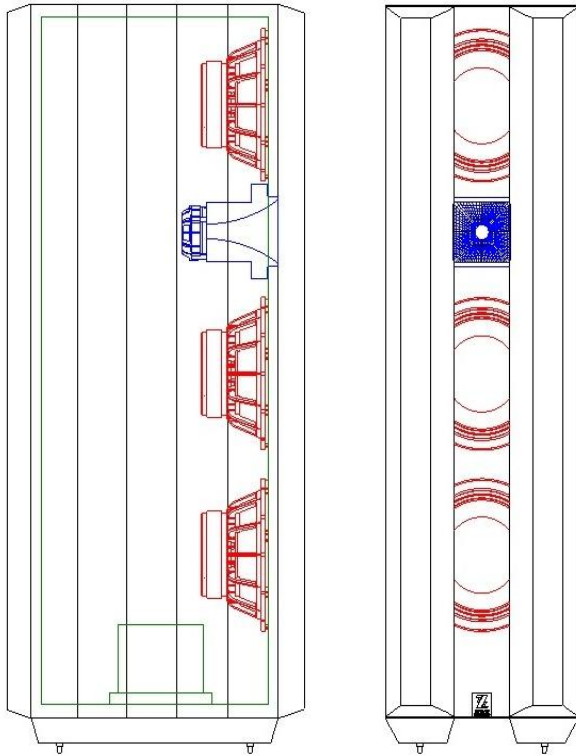

Remaining in our research and innovation philosophy, in 2018 we gave rise to a new technology called **Kompressor Array** and registered all over the world.

This technology is an evolution of our old *Omniray* project in which the new feature is to phase and line all the speakers by combining them into a single horn mouth.

Our new **Kompressor Array** technology has the ability to control the emission of the entire sound spectrum: low frequencies and medium-high frequencies, keeping the sound beam in a dispersion angle of 90 degrees total (Graphic A).

This allows us to reduce the reflection effects of sounds when listening to systems in a domestic environment. Unlike *Omniray* technology which controlled exclusively medium-high frequencies.

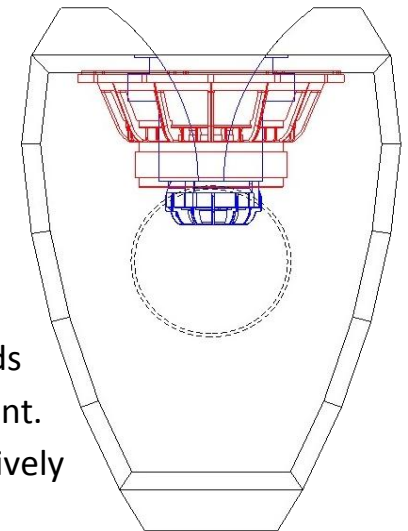

In conventional loudspeakers, which use a mid cone speaker and a dome tweeter, on the other hand, there is a dispersion at 180 degrees (Graphic B), which generates a reflection effect mixed with the direct one and the sound spectrum that will arrive at the listening point will be therefore uneven. As it is known, in proportion, the low frequencies arrive more than the medium-high frequencies, which are nullified due to the reflections in out-phase.

**Graphic A**

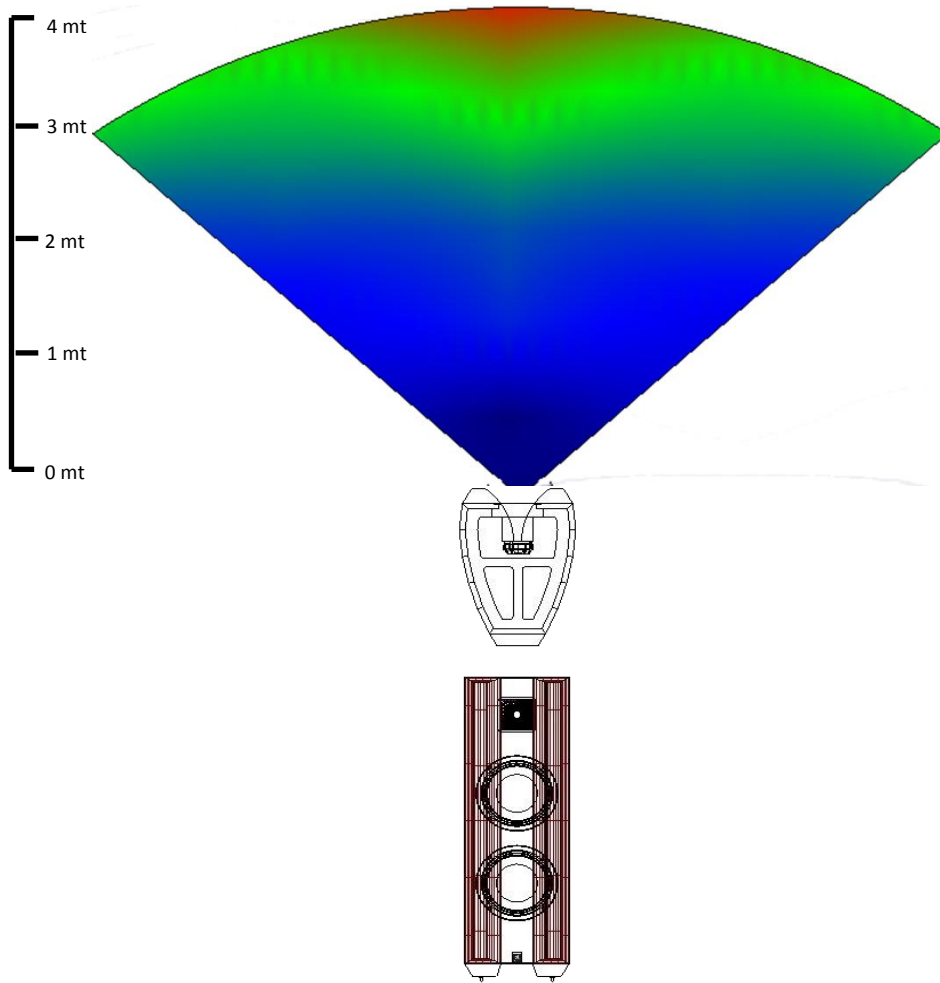

**Zingali Quantum Array 2.8**  
**Kompressor Array Technology**

**Legend**

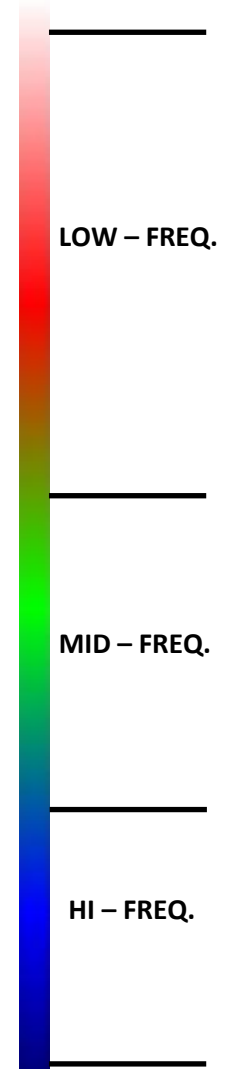

**Graphic B**

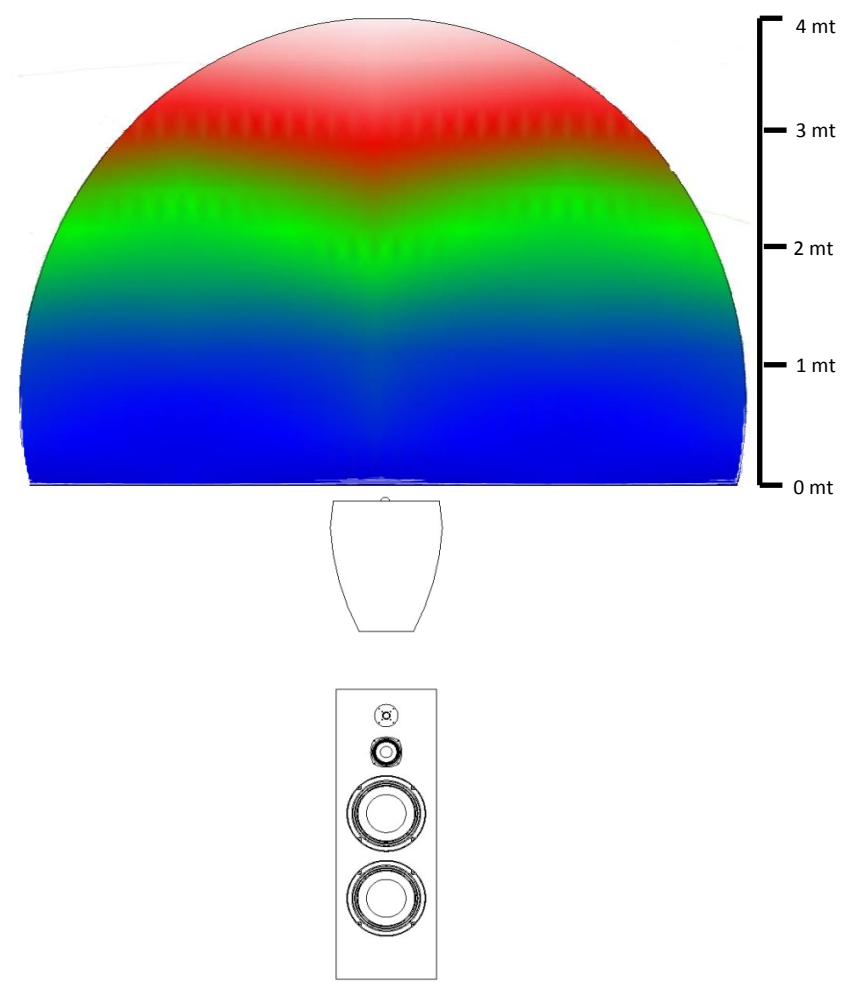

**Conventional Loudspeakers**

As in the other systems, the new **Zingali Tuning Port** is placed on the bottom of the speaker, allowing a greater versatility in positioning the speaker in the listening room.

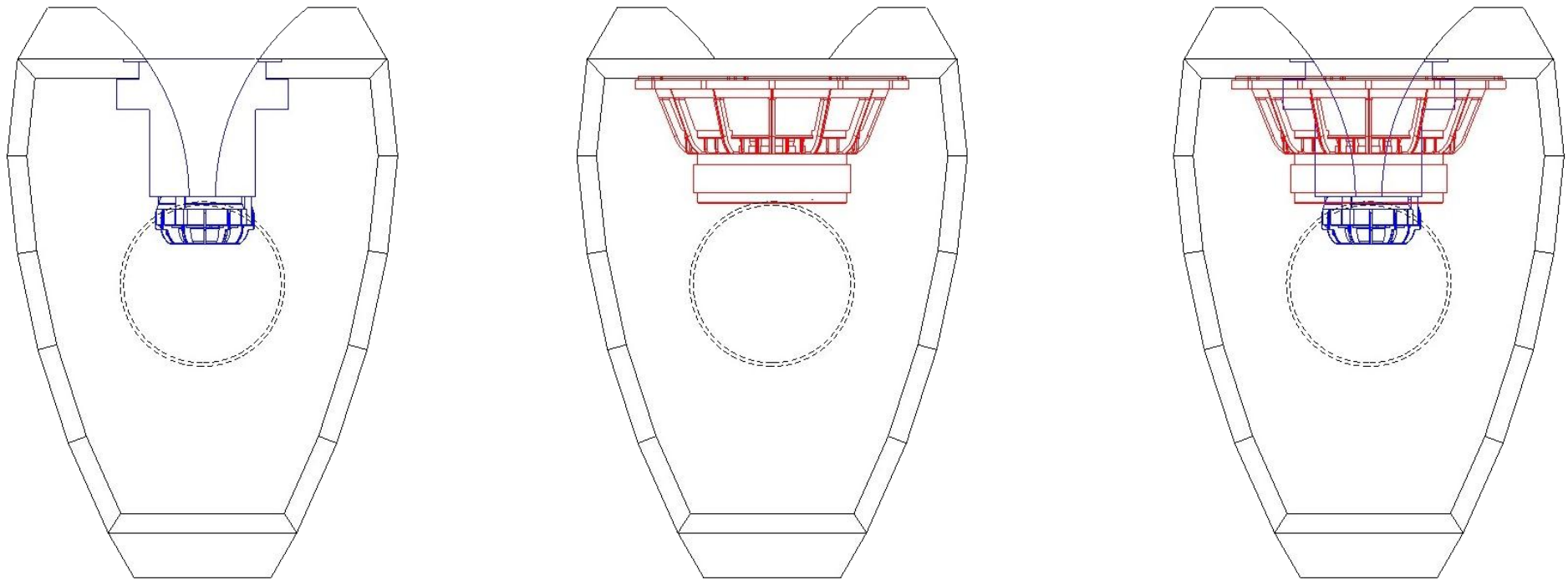

**KOMPRESSOR ARRAY**

*Patented in 2018*

***Thank you and Enjoy your Music!***

***Zingali Acoustics S.p.A.***

Via dell'Industria, 28 - 04011 Aprilia (LT) - Italy

Tel. 06/9282577 - [info@zingaliacoustics.com](mailto:info@zingaliacoustics.com)